

## **RP1 Rega Planar One**

The RP1 has been designed and engineered to achieve outstanding performance way beyond the expectations of a product at this price point. Excellent build quality, reliability and ease of use combine to make a product which if used correctly will offer you a lifetime of musical enjoyment.

Omitting all the usual gimmicks allows us to concentrate the manufacturing costs on the high quality parts necessary to accurately reproduce music from vinyl. Using a manual speed change rather than an automatic mechanism eliminates speed inconsistencies and reduces wear of the drive belt. The money we save is spent across the design including a hand assembled RB101 tonearm, precision main bearing and a high quality, low vibration motor which would normally be used on a turntable costing many times the amount. The minimalist design of the Rega RP1 and the use of extremely high quality components ensure that your turntable should last for many years. The tips on the reverse of these instructions will help increase the life of your turntable and ensure optimum performance.

### **Manual speed change 33 RPM 45 RPM**

You can change playing speed by simply removing the platter and moving the belt to either the 33rpm or 45rpm wheel of the drive pulley see fig 1.

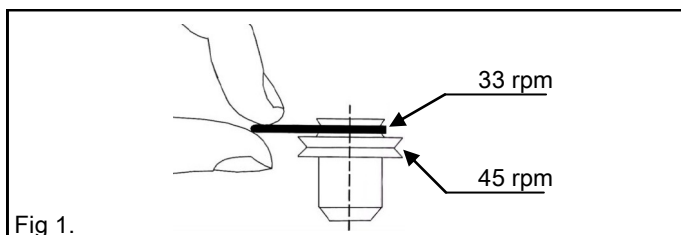

### **Connection to the amplifier**

The external phono leads must be connected to your amplifier. Connections : **Red** right channel / **Black** left channel. If your amplifier does not have an integrated phono stage you will require an external stage such as the Rega FONO mini.

### **Plug and play - Quick set up ( factory fitted cartridge only )**

Your turntable has been designed to be very simple to set-up and use. We have designed this turntable so that correct tracking weight can be achieved by simply pushing the balance weight as close to the stop point as possible. Fig 2. This will automatically set the arm to within the recommended tracking range for the factory fitted stylus. The Bias slider should be set to 2 when using the Rega Carbon. Fig 3.

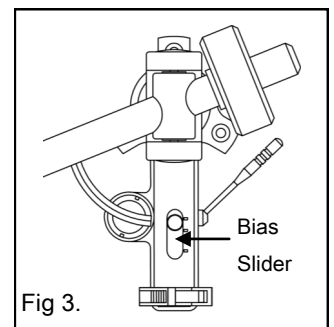
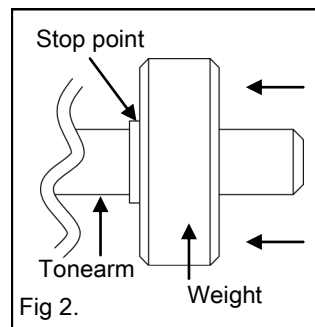

### **Advanced Set-up ( if using a different model of cartridge )**

If you choose to change the factory fitted cartridge, a tracking pressure gauge is required to correctly apply the required down force. Any Hi-Fi dealer should be happy to help with this setup procedure when you purchase a new cartridge. Always use a down force which corresponds to the upper limit of the cartridge maker's recommended range. A new cartridge must be aligned correctly as shown in fig 4. Adjust the cartridge position in the head-shell so that the stylus tip is vertically aligned with the front of the hole marked **A**. Ensure the cartridge is sitting square in the head-shell before fully tightening. (Take care not to over tighten ). Set the bias adjustment slider fig 3. to the same number as the tracking force. For example 2.0g tracking force = 2.0 on the bias slider.

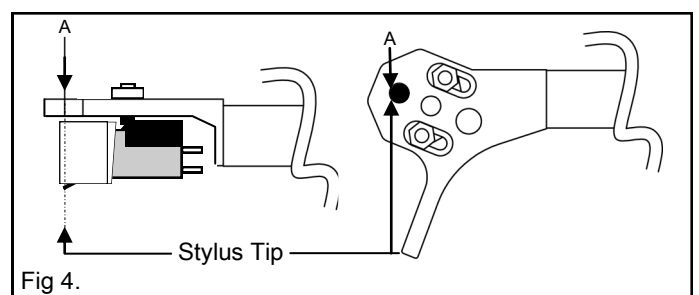

# RP1

Mount the turntable on a rigid, level surface. Avoid mounting on hollow or heavy cabinets or anything mounted on a flexible wooden floor. The Rega turntable support is the ideal solution.

Keeping the lid closed while playing records will prevent dust falling onto the record surface and should make cleaning unnecessary. Depending on the room environment and ambient temperature, playing with the lid open may offer sonic improvements. You can experiment to optimise the performance best suited to your room.

Do not use any record cleaner that works while the record is playing or any cleaners that use water or solvents. If you keep your records stored in their sleeves, avoid touching the playing surfaces and keep all water and fluids away, cleaning should not be necessary. Do not worry about visible dust on the record surface, as this is brushed aside during playback and any that collects on the stylus can be easily blown away. In general, record cleaning is overdone and one should not believe all the claims made by record cleaner manufacturers.

Leave the turntable running during a record playing session. Switch on before the session and only switch off after you have finished. This will increase the life of the motor and drive belt.

Do not lift the centre hub out from the main bearing. The bearing is factory assembled with a film of special thick lubricant. If the centre hub is removed this film may be disturbed and the accuracy of the turntable could be affected.

The arm earth (or ground) is automatically connected through the arm cable screening. No other earthing should be necessary.

Save the original packing in case you ever need to transport the turntable.

Do not use any polish on the turntable or lid. To clean, wipe gently with a soft cotton duster (slightly damp only if required).

Rega turntables are designed to optimise performance for music reproduction and therefore no compromises have been made to give quick start times. The normal time taken for full speed to be reached is between 2 and 5 seconds.

**Warning:** Any attempt to repair or modify this turntable by persons other than Rega personnel may invalidate the guarantee. Should you experience any problem with your turntable, please contact your Rega dealer.

## Rega upgrades for the RP1 turntable

**RP1 Performance Pack**

**Upgrade Drive Belt**

**Turntable wall bracket**

**Fono Mini A2D MM phono stage with USB.**

**Fono MM phono stage**

Full details of these products and upgrades are available on [www.rega.co.uk](http://www.rega.co.uk) or from your Rega dealer. Thank you for purchasing the RP1 designed, built and manufactured in England.